



# Brass Metropolis

## stage plot/input list

### What we DO need:

- FOH Speakers (and Power)
- Speaker management for our L/R feed
- 28 XLR Cables
- (2) Boom Mic Stands
- AC Power Drops  

### We DO NOT need:

- FOH Console
- Risers
- Monitoring Equipment
- Any Microphones or D.I.s

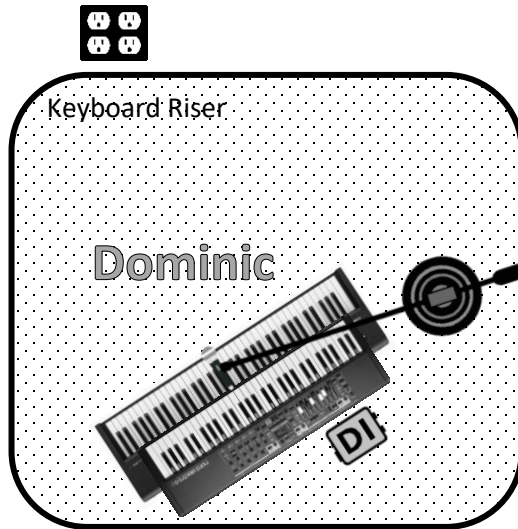

Guitar Amp  
D.I. next to amp.

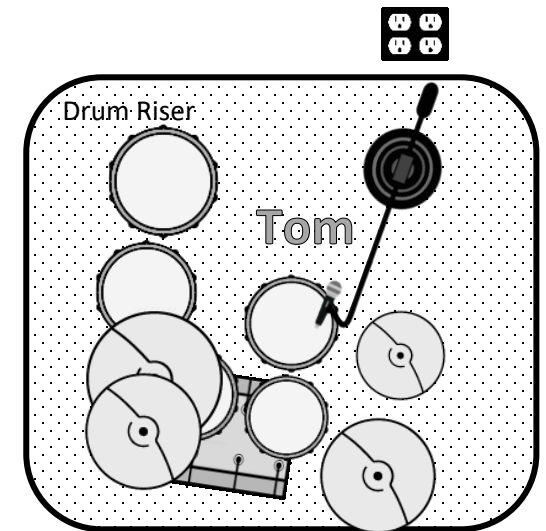
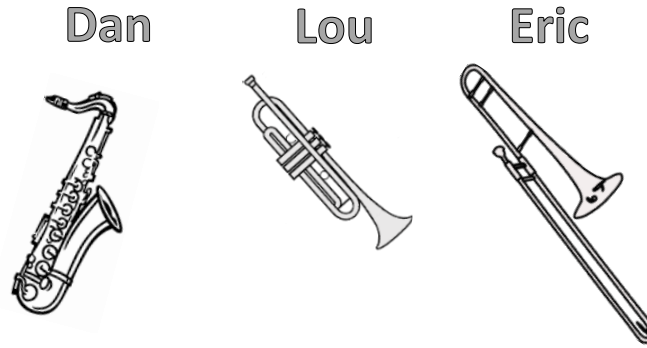

Bass Amp  
D.I. on front of head.



	<b>Input Channels</b>		<b>PROVIDED Microphone/D.I.</b>
<b>Drums</b>	<b>1</b>	Kick	Audix D6 (in drum)
	<b>2</b>	Snare	Audix i5
	<b>3</b>	Hi-Hat	Rode NT5
	<b>4</b>	Tom 1	Audix D2
	<b>5</b>	Tom 2	Audix D2
	<b>6</b>	Tom 3	Audix D4
	<b>7</b>	Tom 4	Audix D4
	<b>8</b>	Ride Cymbal	Rode NT5
<b>Aux Perc</b>	<b>9</b>	Auxiliary Percussion	Heil PR20
<b>Bass</b>	<b>10</b>	Bass	D.I. (on front of head)
<b>Guitar</b>	<b>11</b>	Guitar	D.I. (next to amp)
<b>Keyboards</b>	<b>12</b>	Nord Stage EX (piano)	D.I. provided
	<b>13</b>	Nord Electro 6 (organ)	D.I. provided
<b>Horns</b>	<b>16</b>	Flute	NUX B6
	<b>17</b>	Saxophone	AMT LS
	<b>18</b>	Trumpet	AMT P800
	<b>19</b>	Trombone	AMT P808
<b>Vocals</b>	<b>20</b>	Dominic (keyboards)	Audix OM6
	<b>21</b>	Lake (guitar)	Heil PR35
	<b>22</b>	Rocco (lead vox/bass)	Heil PR35
	<b>23</b>	Doug (lead vox)	Heil PR35
	<b>24</b>	TJ (drums)	Heil PR35

**Contacts:**

Band Leader - Rocco (330) 519-4366

Tech Director - Joe (330) 746-6773